

## DOOR PREP

1. Install door
2. Locate horizontal centerline on door
3. Verify backset (2-3/4", 5" or 7"). Tape template to door.

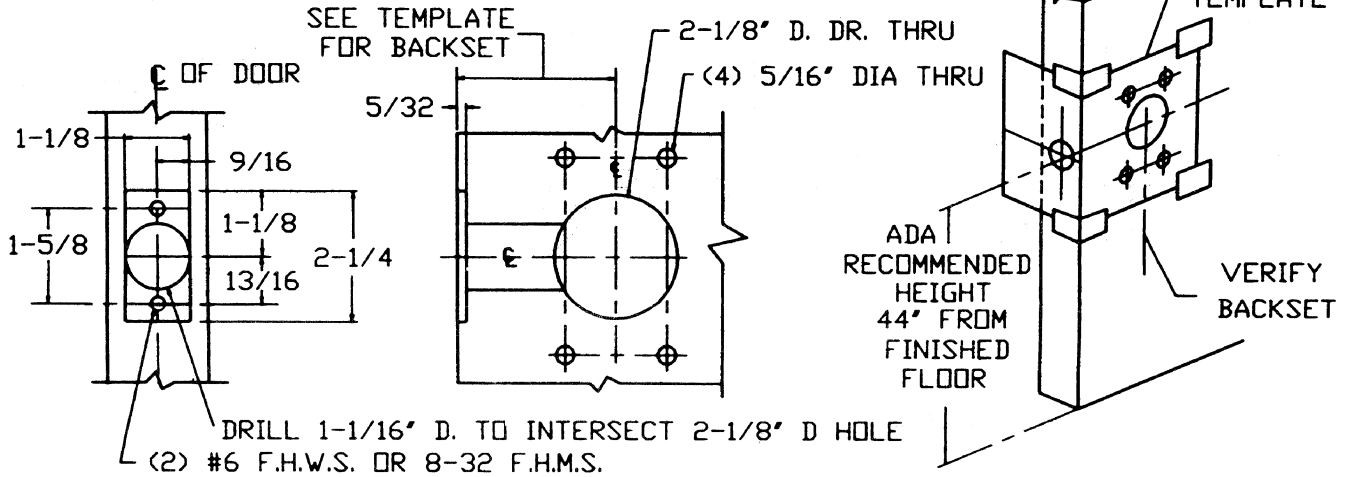

## FRAME PREP

1. Mark centerline of latch bolt on frame
2. Center strike and mark screw positions
3. Mortise to required strike and box depth

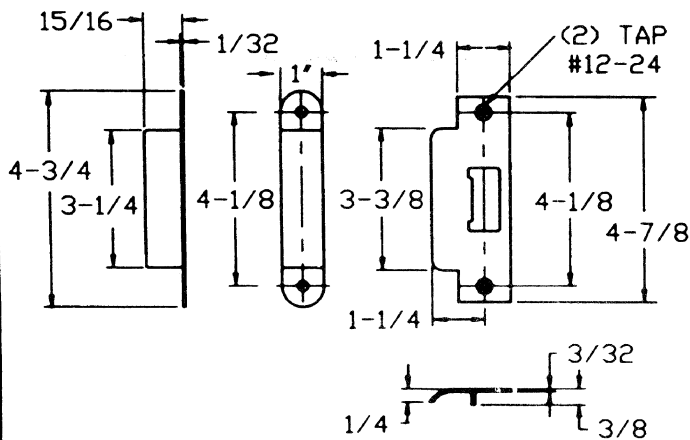
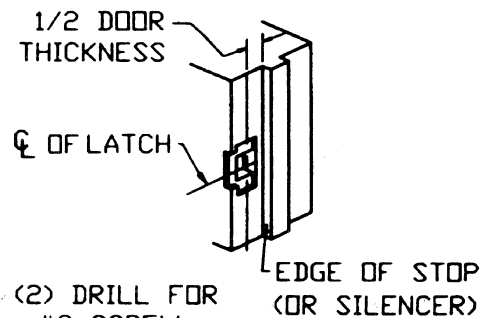

ASA STRIKE & BOX

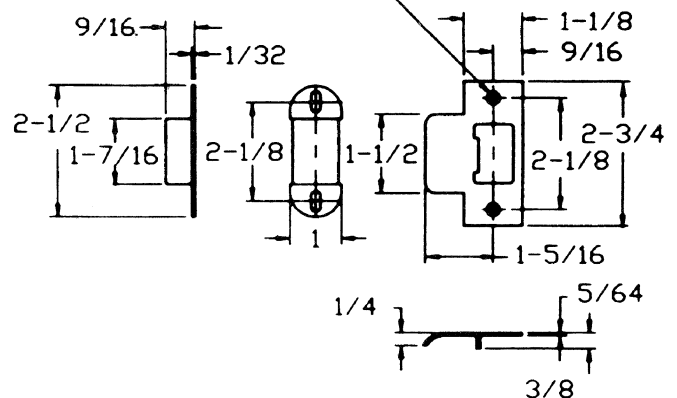

STANDARD STRIKE & BOX

## LATCH/HANDLE ASSEMBLY

1. Install latch bolt.  
Radius portion of latch bolt must face push side of door.
2. Install pull side handle assembly\* with latch shaft thru latch bolt assembly.
3. Mount push side handle\* and install (4) 10-32 X 2-3/4" screws with nuts.
4. Mount Cover.

\* CAM PIN MUST BE ROTATED TOWARD SIDE INDICATED BY ARROW STAMPED ON BASE  
SEE DRAWING ON FRONT OF TEMPLATE

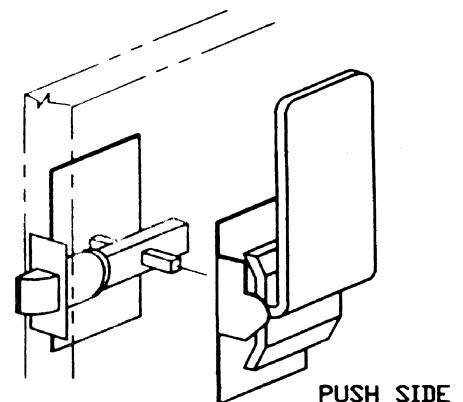

ALL DIMENSIONS IN INCHES